

MISCELLANEOUS

55. EGRESS WINDOWS. Section R310 IRC 2009

R310.1 Emergency escape and rescue required. *Basements*, habitable attics and every sleeping room shall have at least one operable emergency escape and rescue opening. Where *basements* contain one or more sleeping rooms, emergency egress and rescue openings shall be required in each sleeping room. Where emergency escape and rescue openings are provided they shall have a sill height of not more than 44 inches (1118 mm) above the floor. Where a door opening having a threshold below the adjacent ground elevation serves as an emergency escape and rescue opening and is provided with a bulkhead enclosure, the bulkhead enclosure shall comply with Section R310.3. The net clear opening dimensions required by this section shall be obtained by the normal operation of the emergency escape and rescue opening from the inside. Emergency escape and rescue openings with a finished sill height below the adjacent ground elevation shall be provided with a window well in accordance with Section R310.2. Emergency escape and rescue openings shall open directly into a public way, or to a *yard* or court that opens to a public way.

Exception: *Basements* used only to house mechanical *equipment* and not exceeding total floor area of 200 square feet (18.58 m²).

R310.1.1 Minimum opening area. All emergency escape and rescue openings shall have a minimum net clear opening of 5.7 square feet (0.530 m²).

Exception: Grade floor openings shall have a minimum net clear opening of 5 square feet (0.465 m²).

R310.1.2 Minimum opening height. The minimum net clear opening height shall be 24 inches (610 mm).

R310.1.3 Minimum opening width. The minimum net clear opening width shall be 20 inches (508 mm).

R310.1.4 Operational constraints. Emergency escape and rescue openings shall be operational from the inside of the room without the use of keys, tools, or special knowledge.

R310.2 Window wells. The minimum horizontal area of the window well shall be 9 square feet (0.84 m²), with a minimum horizontal projection and width of 36 inches (914 mm). The area of the window well shall allow the emergency escape and rescue opening to be fully opened.

Exception: The ladder or steps required by Section R310.2.1 shall be permitted to encroach a maximum of 6 inches (152 mm) into the required dimensions of the window well.

R310.2.1 Ladder and steps. Window wells with a vertical depth greater than 44 inches (1118 mm) shall be equipped with a permanently affixed ladder or steps usable with the window in the fully open position. Ladders or steps required by this section shall not be required to comply with Sections R311.5 and R311.6. Ladders or rungs shall have an inside width of at least 12 inches (305 mm), shall project at least 3 inches (76 mm) from the wall and shall be spaced not more than 18 inches (457 mm) on center vertically for the full height of the window well.

R310.3 Bulkhead enclosures. Bulkhead enclosures shall provide direct access to the basement. The bulkhead enclosure with the door panels in the fully open position shall provide the minimum net clear opening required by Section R310.1.1. Bulkhead enclosures shall also comply with Section R314.9.

R310.4 Bars, grills, covers and screens. Bars, grills, covers, screens or similar devices are permitted to be placed over emergency escape and rescue openings, bulkhead enclosures, or window wells that serve such openings, provided the minimum net clear opening size complies with Sections R310.1.1 to R310.1.3, and such devices shall be releasable or removable from the inside without the use of a key, tool, special knowledge, or force greater than that which is required for normal operation of the escape and rescue opening.

R310.5 Emergency Escape Windows under Decks and Porches. Emergency escape windows are allowed to be installed under decks and porches provided the location of the deck allows the emergency escape window to be fully opened and provides a path not less than 36 inches (914 mm) in height to a yard or court.

57. SMOKE DETECTION AND NOTIFICATION: R314.1 IRC 2009

R314.1 Smoke detection and notification. All smoke alarms shall be listed in accordance with UL 217 and installed in accordance with the provisions of this code and the household fire warning *equipment* provisions of NFPA 72.

R314.2 Smoke detection systems. Household fire alarm systems installed in accordance with NFPA 72 that include smoke alarms, or a combination of smoke detector and audible notification device installed as required by this section for smoke alarms, shall be permitted. The household fire alarm system shall provide the same level of smoke detection and alarm as required by this section for smoke alarms. Where a household fire warning system is installed using a combination of smoke detector and audible notification device(s), it shall become a permanent fixture of the occupancy and owned by the homeowner. The system shall be monitored by an *approved* supervising station and be maintained in accordance with NFPA 72.

Exception: Where smoke alarms are provided meeting the requirements of Section R314.4.

R314.3 Location.

Smoke alarms shall be installed in the following locations:

1. In each sleeping room.
2. Outside each separate sleeping area in the immediate vicinity of the bedrooms.
3. On each additional story of the dwelling, including basements but not including crawl spaces and uninhabitable attics. In dwellings or dwelling units with split levels and without an intervening door between the adjacent levels, a smoke alarm installed on the upper level shall suffice for the adjacent lower level provided that the lower level is less than one full story below the upper level.

When more than one smoke alarm is required to be installed within an individual dwelling unit the alarm devices shall be interconnected in such a manner that the actuation of one alarm will activate all of the alarms in the individual unit.

R314.3.1 Alterations, repairs and additions. When *alterations*, repairs or *additions* requiring a *permit* occur, or when one or more sleeping rooms are added or created in existing *dwellings*, the individual *dwelling unit* shall be equipped with smoke alarms located as required for new *dwellings*.

Exceptions:

1. Work involving the exterior surfaces of *dwellings*, such as the replacement of roofing or siding, or the *addition* or replacement of windows or doors, or the *addition* of a porch or deck, are exempt from the requirements of this section.
2. Installation, *alteration* or repairs of plumbing or mechanical systems are exempt from the requirements of this section.

R314.4 Power source. Smoke alarms shall receive their primary power from the building wiring when such wiring is served from a commercial source, and when primary power is interrupted, shall receive power from a battery. Wiring shall be permanent and without a disconnecting switch other than those required for overcurrent protection. Smoke alarms shall be interconnected.

Exceptions:

1. Smoke alarms shall be permitted to be battery operated when installed in buildings without commercial power.
2. Interconnection and hard-wiring of smoke alarms in existing areas shall not be required where the *alterations* or repairs do not result in the removal of interior wall or ceiling finishes exposing the structure, unless there is an *attic*, crawl space or *basement* available which could provide access for hard wiring and interconnection without the removal of interior finishes.

58. CARBON MONOXIDE ALARMS. Section 315 IRC 2009 Washington State Amendment

R315.1 Carbon monoxide alarms. For new construction, an approved carbon monoxide alarm shall be installed by January 1, 2011, outside of each separate sleeping area in the immediate vicinity of the bedrooms in dwelling units. In a building where a tenancy exists, the tenant shall maintain the CO alarm as specified by the manufacturer including replacement of the batteries.

R315.2 Existing dwellings. Existing dwellings shall be equipped with carbon monoxide alarms by July 1, 2011.

Exceptions: Owner-occupied detached one-family dwellings legally occupied prior to July 1, 2010.

R315.3 Alarm requirements. Single station carbon monoxide alarms shall be listed as complying with UL 2034 and shall be installed in accordance with this code and the manufacturer's installation instructions.

59. SEPARATION FROM HOUSE TO ATTACHED GARAGE. Section R302.6 IRC 2009

R302.6 Dwelling/garage fire separation. The garage shall be separated as required by Table R302.6. Openings in garage walls shall comply with Section R302.5. This provision does not apply to garage walls that are perpendicular to the adjacent *dwelling unit* wall.

R302.5 Dwelling/garage opening/penetration protection. Openings and penetrations through the walls or ceilings separating the *dwelling* from the garage shall be in accordance with Sections R302.5.1 through R302.5.3.

R302.5.1 Opening protection. Openings from a private garage directly into a room used for sleeping purposes shall not be permitted. Other openings between the garage and residence shall be equipped with solid wood doors not less than 1 3/8 inches (35 mm) in thickness, solid or honeycomb core steel doors not less than 1 3/8 inches (35 mm) thick, or 20-minute fire-rated doors.

R302.5.2 Duct penetration. Ducts in the garage and ducts penetrating the walls or ceilings separating the *dwelling* from the garage shall be constructed of a minimum No. 26 gage (0.48 mm) sheet steel or other *approved* material and shall have no openings into the garage.

R302.5.3 Other penetrations. Penetrations through the separation required in Section R309.2 shall be protected as required by Section R302.11, Item 4.

60. NATURAL LIGHT. Section R303.1 IRC 2009

R303.1 Habitable rooms. All habitable rooms shall be provided with aggregate glazing area of not less than 8 percent of the floor area of such rooms. Natural ventilation shall be through windows, doors, louvers or other approved openings to the outdoor air. Such openings shall be provided with ready access or shall otherwise be readily controllable by the building occupants. The minimum openable area to the outdoors shall be 4 percent of the floor area being ventilated.

Exceptions:

1. The glazed areas need not be openable where the opening is not required by Section R310 and an approved mechanical ventilation system is provided capable of producing 0.35 air change per hour in the room or a whole-house mechanical ventilation system is installed capable of supplying outdoor ventilation air of 15 cubic feet per-minute (cfm) (7.08L/s) per occupant computed on the basis of two occupants for the first bedroom and one occupant for each additional bedroom.
2. The glazed areas need not be provided in rooms where Exception 1 above is satisfied and artificial light is provided capable of producing an average illumination of 6 foot candles (6.46 lux) over the area of the room at a height of 30 inches (762 mm) above the floor level.
3. Use of sunroom additions and patio covers, as defined in Section R202, shall be permitted for natural ventilation if in excess of 40 percent of the exterior sunroom walls are open, or are enclosed only by insect screening.

61. SAFETY GLAZING. Section R308 IRC 2009

R308.3 Human impact loads. Individual glazed areas, including glass mirrors in hazardous locations such as those indicated as defined in Section R308.4, shall pass the test requirements of Section R308.3.1.

Exceptions:

1. Louvered windows and jalousies shall comply with Section R308.2.
2. Mirrors and other glass panels mounted or hung on a surface that provides a continuous backing support.
3. Glass unit masonry complying with Section R610.

R308.3.1 Impact test. Where required by other sections of the code, glazing shall be tested in accordance with CPSC 16 CFR 1201. Glazing shall comply with the test criteria for Category I or II as indicated in Table R308.3.1(1).

Exception: Glazing not in doors or enclosures for hot tubs, whirlpools, saunas, steam rooms, bathtubs and showers shall be permitted to be tested in accordance with ANSI Z97.1. Glazing shall comply with the test criteria for Class A or Bas indicated in Table R308.3.1 (2).

R308.4 Hazardous locations. The following shall be considered specific hazardous locations for the purposes of glazing:

1. Glazing in all fixed and operable panels of swinging, sliding and bifold doors.

Exceptions:

1. Glazed openings of a size through which a 3-inch diameter (76 mm) sphere is unable to pass.
2. Decorative glazing.
2. Glazing in an individual fixed or operable panel adjacent to a door where the nearest vertical edge is within a 24-inch (610 mm) arc of the door in a closed position and whose bottom edge is less than 60 inches (1524 mm) above the floor or walking surface.

Exceptions:

1. Decorative glazing.
2. When there is an intervening wall or other permanent barrier between the door and the glazing.
3. Glazing in walls on the latch side of and perpendicular to the plane of the door in a closed position.
4. Glazing adjacent to a door where access through the door is to a closet or storage area 3 feet (914 mm) or less in depth.
5. Glazing that is adjacent to the fixed panel of patio doors.
3. Glazing in an individual fixed or operable panel that meets all of the following conditions:
 - 3.1. The exposed area of an individual pane is larger than 9 square feet (0.836 m²); and
 - 3.2. The bottom edge of the glazing is less than 18 inches (457 mm) above the floor; and
 - 3.3. The top edge of the glazing is more than 36 inches (914 mm) above the floor; and
 - 3.4. One or more walking surfaces are within 36 inches (914 mm), measured horizontally and in a straight line, of the glazing.

Exceptions:

1. Decorative glazing.
2. When a horizontal rail is installed on the accessible side(s) of the glazing 34 to 38 inches (864 to 965) above the walking surface. The rail shall be capable of withstanding a horizontal load of 50 pounds per linear foot (730 N/m) without contacting the glass and be a minimum of 1 1/2 inches (38 mm) in cross sectional height.
3. Outboard panes in insulating glass units and other multiple glazed panels when the bottom edge of the glass is 25 feet (7620 mm) or more above *grade*, a roof, walking surfaces or other horizontal [within 45 degrees (0.79 rad) of horizontal] surface adjacent to the glass exterior.
4. All glazing in railings regardless of area or height above a walking surface. Included are structural baluster panels and nonstructural infill panels.
5. Glazing in enclosures for or walls facing hot tubs, whirlpools, saunas, steam rooms, bathtubs and showers where the bottom exposed edge of the glazing is less than 60 inches (1524 mm) measured vertically above any standing or walking surface.

Exception: Glazing that is more than 60 inches (1524mm), measured horizontally and in a straight line, from the waters edge of a hot tub, whirlpool or bathtub.

6. Glazing in walls and fences adjacent to indoor and outdoor swimming pools, hot tubs and spas where the bottom edge of the glazing is less than 60 inches (1524 mm) above a walking surface and within 60 inches (1524 mm), measured horizontally and in a straight line, of the water's edge. This shall apply to single glazing and all panes in multiple glazing.
7. Glazing adjacent to stairways, landings and ramps within 36 inches (914 mm) horizontally of a walking surface when the exposed surface of the glazing is less than 60 inches (1524 mm) above the plane of the adjacent walking surface.

Exceptions:

1. When a rail is installed on the accessible side(s) of the glazing 34 to 38 inches (864 to 965 mm) above the walking surface.

The rail shall be capable of withstanding a horizontal load of 50 pounds per linear foot (730 N/m) without contacting the glass and be a minimum of 1 1/2 inches (38 mm) in cross sectional height.

2. The side of the stairway has a guardrail or handrail, including balusters or in-fill panels, complying with Sections R311.7.6 and R312 and the plane of the glazing is more than 18 inches (457 mm) from the railing; or
 3. When a solid wall or panel extends from the plane of the adjacent walking surface to 34 inches (863 mm) to 36 inches (914 mm) above the walking surface and the construction at the top of that wall or panel is capable of withstanding the same horizontal load as a *guard*.
8. Glazing adjacent to stairways within 60 inches (1524 mm) horizontally of the bottom tread of a stairway in any direction when the exposed surface of the glazing is less than 60 inches (1524 mm) above the nose of the tread.

Exceptions:

1. The side of the stairway has a guardrail or handrail, including balusters or in-fill panels, complying with Sections R311.7.6 and R312 and the plane of the glass is more than 18 inches (457 mm) from the railing; or
2. When a solid wall or panel extends from the plane of the adjacent walking surface to 34 inches (864 mm) to 36 inches (914 mm) above the walking surface and the construction at the top of that wall or panel is capable of withstanding the same horizontal load as a *guard*.

61. EXTERIOR DOORS - WIDTH AND HEIGHT. Section R311.2 IRC 2009

R311.2 Egress door. At least one egress door shall be provided for each *dwelling* unit. The egress door shall be side-hinged, and shall provide a minimum clear width of 32 inches (813 mm) when measured between the face of the door and the stop, with the door open 90 degrees (1.57 rad). The minimum clear height of the door opening shall not be less than 78 inches (1981 mm) in height measured from the top of the threshold to the bottom of the stop. Other doors shall not be required to comply with these minimum dimensions. Egress doors shall be readily openable from inside the *dwelling* without the use of a key or special knowledge or effort.

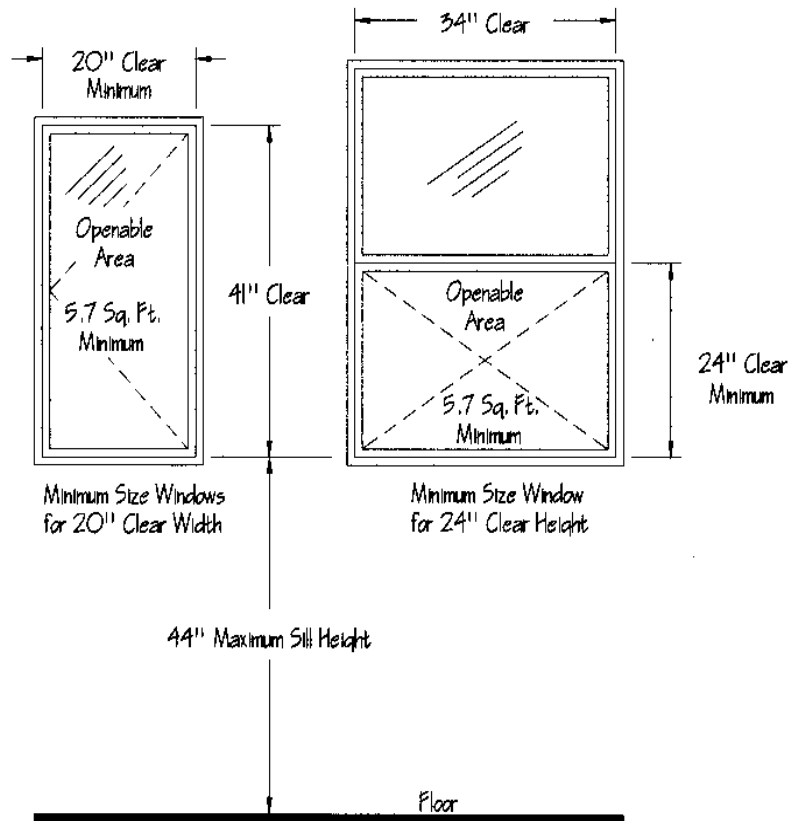

MINIMUM SIZED RESCUE OR ESCAPE WINDOWS FROM SLEEPING ROOMS

Section 310 IRC 2009

RESCUE OR ESCAPE WINDOW WELLS

Rescue and escape windows with a finished sill height below the adjacent ground elevation shall have a window well. Window wells at rescue or escape windows shall comply with the following:

1. The clear horizontal dimensions shall allow the window to fully open and provide a minimum accessible net clear opening of 9 square feet, with a minimum dimension of 36 inches.
2. Window wells with a vertical depth of more than 44 inches shall be equipped with an approved permanently affixed ladder or stairs that are accessible with the window in the fully opened position. The ladder or stairs shall not encroach into the required dimensions of the window well more than 6 inches.

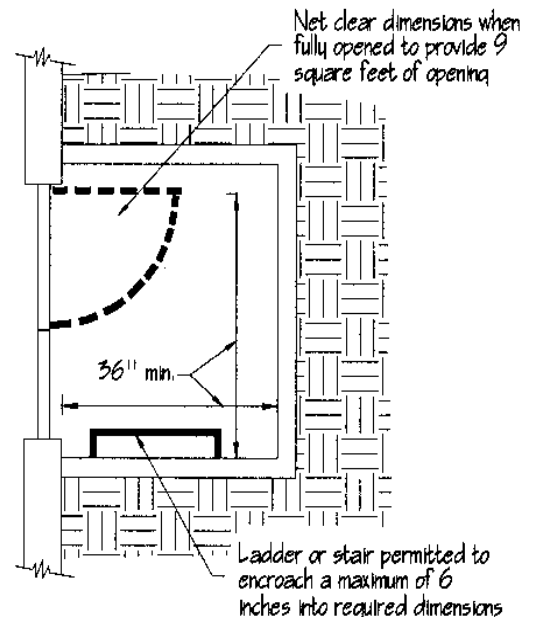

RADON REQUIREMENTS

Appendix F IRC 2009

AF103.6 Passive subslab depressurization system. In *basement* or slab-on-grade buildings, the following components of a passive sub-slab depressurization system shall be installed during construction.

AF103.6.1 Vent pipe. A minimum 3-inch-diameter (76 mm) ABS, PVC or equivalent gas-tight pipe shall be embedded vertically into the sub-slab aggregate or other permeable material before the slab is cast. A “T” fitting or equivalent method shall be used to ensure that the pipe opening remains within the sub-slab permeable material. Alternatively, the 3-inch (76 mm) pipe shall be inserted directly into an interior perimeter drain tile loop or through a sealed sump cover where the sump is exposed to the sub-slab aggregate or connected to it through a drainage system. The pipe shall be extended up through the building floors, terminate at least 12 inches (305 mm) above the surface of the roof in a location at least 10 feet (3048 mm) away from any window or other opening into the *conditioned spaces* of the building that is less than 2 feet (610 mm) below the exhaust point, and 10 feet (3048 mm) from any window or other opening in adjoining or adjacent buildings.

AF103.6.2 Multiple vent pipes. In buildings where interior footings or other barriers separate the sub-slab aggregate or other gas-permeable material, each area shall be fitted with an individual vent pipe. Vent pipes shall connect to a single vent that terminates above the roof or each individual vent pipe shall terminate separately above the roof.

AF103.7 Vent pipe drainage. All components of the radon vent pipe system shall be installed to provide positive drainage to the ground beneath the slab or soil-gas-retarder.

AF103.8 Vent pipe accessibility. Radon vent pipes shall be accessible for future fan installation through an *attic* or other area outside the *habitable space*.

Exception: The radon vent pipe need not be accessible in an *attic* space where an *approved* roof-top electrical supply is provided for future use.

AF103.9 Vent pipe identification. All exposed and visible interior radon vent pipes shall be identified with at least one *label* on each floor and in accessible *attics*. The *label* shall read: “Radon Reduction System.”

AF103.10 Combination foundations. Combination *basement/crawl space* or slab-on-grade/crawl space foundations shall have separate radon vent pipes installed in each type of foundation area. Each radon vent pipe shall terminate above the roof or shall be connected to a single vent that terminates above the roof.

AF103.11 Building depressurization. Joints in air ducts and plenums in *unconditioned spaces* shall meet the requirements of Section M1601. Thermal envelope air infiltration requirements shall comply with the energy conservation provisions in Chapter 11. Firestopping shall meet the requirements contained in Section R602.8.

AF103.12 Power source. To provide for future installation of an active sub-membrane or sub-slab depressurization system, an electrical circuit terminated in an *approved* box shall be installed during construction in the *attic* or other anticipated location of vent pipe fans. An electrical supply shall also be accessible in anticipated locations of system failure alarms.